



BLOODHOUND@University

Dr John Lanham
University of the West of England, Bristol



Introduction

- Introduction
- The Bloodhound Project
 - STEM Enrichment & Engagement
- Bloodhound@University
 - Aims
 - Activities
 - Approach





Where did it start ?

Lord Drayson- Jan.9th 2007 .

Experiencing a shortage of engineers into the MOD, Lord Drayson, Minister for Defence Equipment and Support indicates that he would be keen to see a new iconic British high technology project to stimulate national interest in engineering technology in schools.



The current situation

There are serious current problems with supply of engineers

- Following examples have demonstrated serious shortages
- Airbus
- Astrium
- Npower
- EDF
- Rolls-Royce
- Ministry of Defence

Reality- ETB report Dec. 2007

- Forecast decline in 16 & 18 years cohorts (-16% & -13%) in next decade will affect employers
- GCSE volumes of key subjects have been increasing over the last decade
- At GCE A levels the gender gap is slowly reaching parity
- Provisional figures for October 2007 saw a rise in mathematics

Reality : Royal Academy June 2007

- Over next 10 years the UK is facing an increasing shortage of high calibre engineering graduates
- Between 1994-2004 the number of engineering degree starts remained static at 24,500/year while university admissions rose by 40%
- Engineering courses must develop in line with real and constantly evolving requirements of industry
- To fill the pipeline, more must be done to ensure that schools students, parents and teachers perceive engineering as an exciting and worthwhile subject that offers stimulating and well paid careers .



Apollo Effect

Physics PhD's and all PhD's conferred in the US, 1900 to 2006.

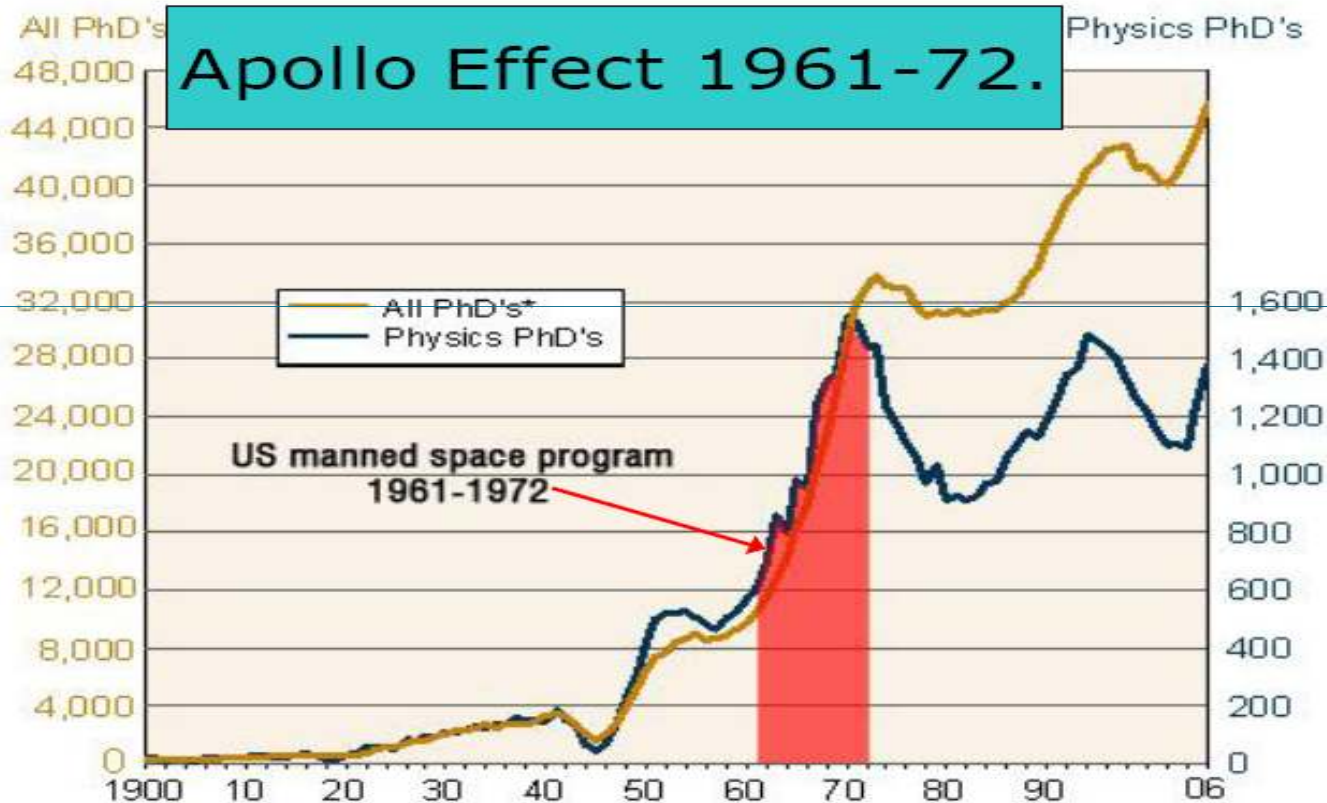

AIP Statistical Research Center, Enrollments and Degrees Survey
* NSF Survey of Eamed Doctorates



WLSR

The World Land Speed Record

- The FIA World Record for the fastest car
- Traditional opposition – the US
- Generates vast global media coverage
- Unlimited design –but must have 4 or more wheels
- Requires very advanced engineering
- Involves 2-300 companies in the supply chain
- Held by Britain for 65 out of 109 years
- The Thrust teams have held the World Land Speed Record for 24 years continuously.



Thrust 2 1983 – 633.468mph M 0.84
ThrustSSC 1997- 763.035mph M1.02

- ThrustSSC: first ever supersonic record-current
- Website peaked at 3.5 million accesses(11m pages/day)
- UK media – 1col/kilometre
- Global media –on satellite television for 10 years .
- Most famous car in the World –purchased by UK lottery .
- \$60m movie in development at Pinewood Studios.
- Currency today :
 - YOUTUBE views 2,785,449.
 - Frozen website still runs 2000 pages /day.





Bloodhound Priorities

Mission Statement:

To:

Confront the impossible and to overcome using Science Engineering Technology and Mathematics .

Why?:

An engineering adventure to inspire prepare and motivate the next generation who will be building and living in the low carbon World .

OBJECTIVES (ranked in importance)

- 1.To create a national surge in popularity of Science and Engineering (STEM subjects)
- 2.To create an iconic project requiring extreme research and technology whilst providing the means to enable the student population to join in the adventure .
- 3.To achieve the first 1000mph record on land
- 4.To generate very substantial and enduring media exposure for sponsors



Making it Happen

Four Year Programme

- **July 2007 - October 2008**
Research programme and Project launch
- **November 2008 - Aug 2009**
Detail design & Vehicle build
- **September / Oct 2009**
800mph target
- **September / Oct 2010**
900mph target
- **September / Oct 2011**
1000mph record

Bloodhound Organisation

- Bloodhound Education Team develops and runs the schools programme
- Bloodhound Engineering develops builds and operates the car
- Bloodhound Communication manages PR communications internet activity and Supporters Club
- Bloodhound Back Office – handles all marketing , accounting company secretary etc



The Car

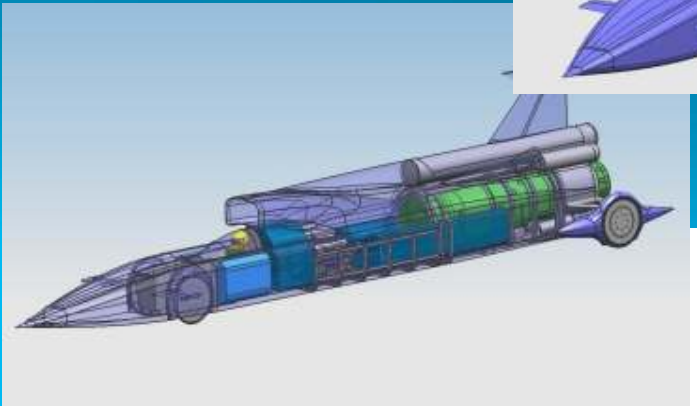
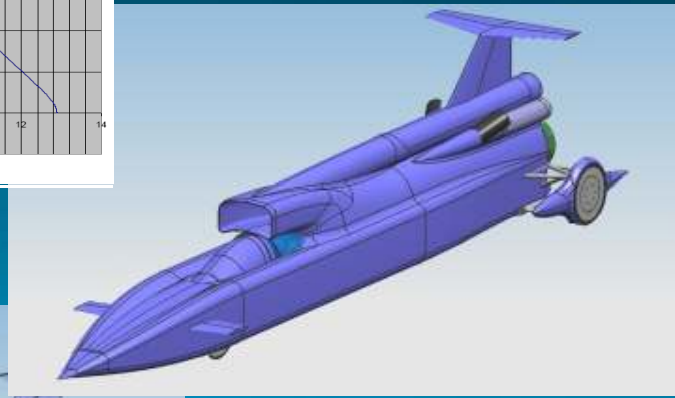
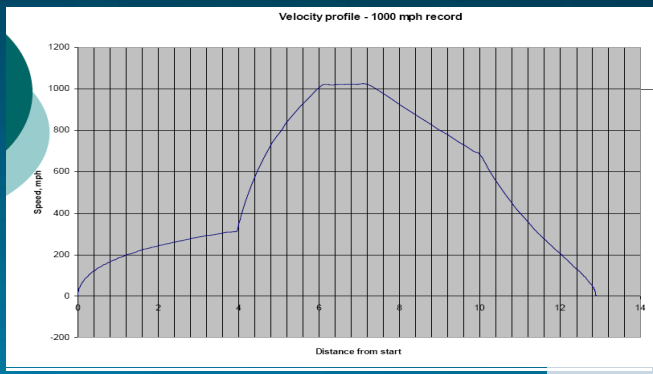



How did we get involved ?

- August 2006 – JCB DieselMax Car
- WLSR – Diesel engine
- 350.092 mph
- John Piper – Chief Design Engineer





Would you like to meet Richard Noble ?

Bloodhound Educational Team

- **Prime Objective: To use Project to encourage school leavers to take up study of Engineering, STEM and enter Engineering related careers**
- 3 year programme main focus – all schools 5-19 years.
- Web driven programme
- Being created and managed by a very small team
- Commences operation November 2008



BET – But no HE !

Bloodhound Educational Team

Chair David Rowley
Founder/Exec Secretary
Education Director
Distribution Director

Royal Academy of Engineering
Joanna Coleman EPSRC
Under recruitment
Under recruitment

Kate Bellingham

Ambassador

John Lanham
Martin Hine
Sally Wilson
Jan Stapleton
Declan Swan

University of West of England
Ministry of Defence
SERCO plc
Institution of Engineering and Technology
National Education Business Partnership
Network

Marcus Wade

Year in Industry Student – support .

Supported by EPSRC, ETB, Royal Academy, G-15 Institutions, ERA



A pleasant surprise – UWE a Founder Sponsor

- Thrust 2 & Thrust SSC Sponsorship model
 - Founder Sponsor – name on the car
 - Product Sponsor – use their name on your products in exchange for “donating” products / services to project.
- June 2008 – UWE signs up as one of five founder sponsors – UWE’s logo will be on the car.



Other Founder Sponsors



Swansea University
Prifysgol Abertawe



serco

EPSRC



University of the
West of England



UWE's Contributions to date

- Housed design team since January 2008
- Manufactured test items
- Visitor Centre Development
 - Multiple iterations !!
- Environmental Evaluation
- Model manufacture
- Bloodhound@University
- Simulator Project – with Southampton



Education / Visitor Centre

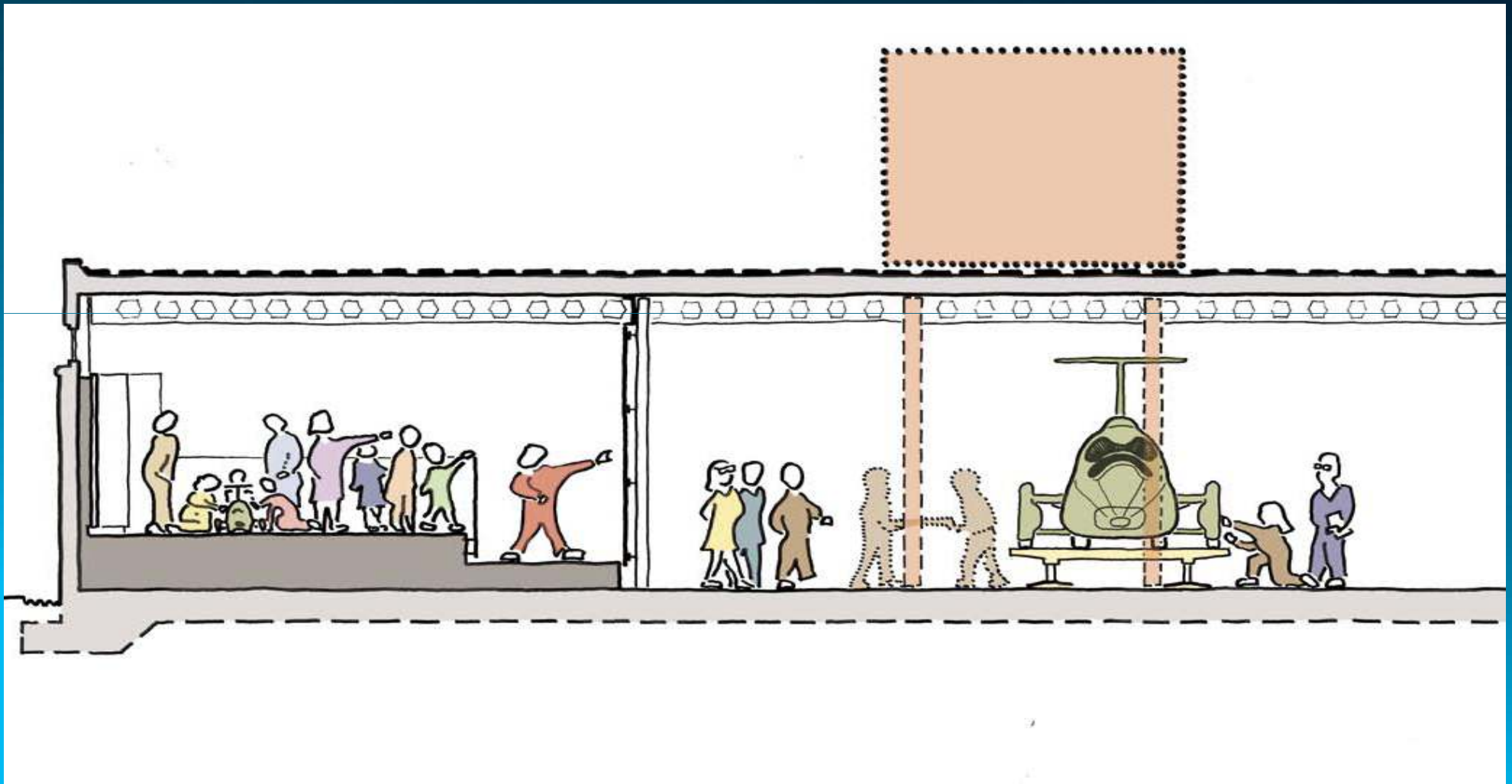



Model Manufacture



- Neil Jones
- Chris Hart



Bloodhound@University

- Objective : Using the Bloodhound project to enhance British engineering higher education
 - Integrate information from the project into HE STEM education
 - Teaching materials, case studies, projects, competitions
 - Web Portal for dissemination

UNIVERSITY OF
Southampton
School of Engineering Sciences



University of the
West of England



Swansea University
Prifysgol Abertawe



Unique access to what & why ?

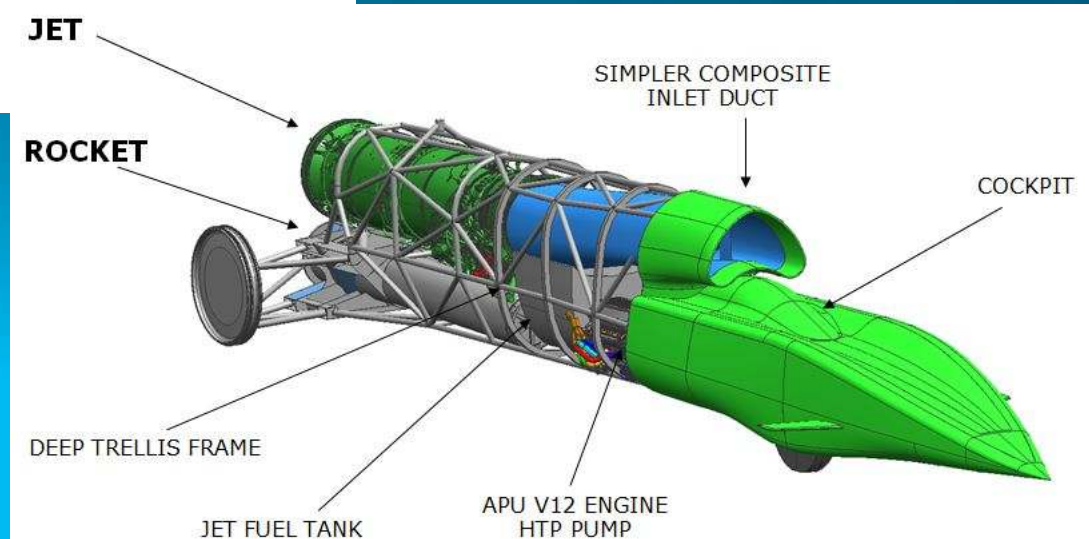
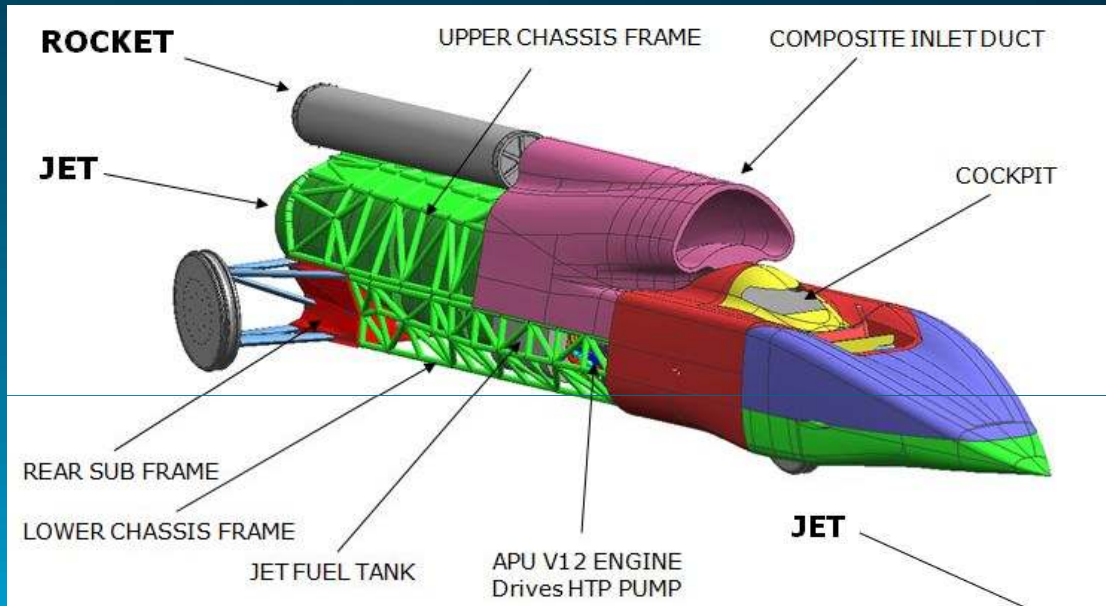



Higher Education Working Together



University of the West of England



Swansea University
Prifysgol Abertawe



UNIVERSITY OF BIRMINGHAM

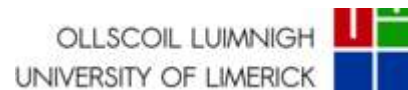

The Open University





Initial HE Facing projects

Housing Mock-Up build

Student Design Projects—
Cockpit Ergonomics
Turn-round planning

Bloodhound@University Web
portal





Bloodhound Placements

BLOODHOUND SSC
ENGINEERING ADVENTURE

COCKPIT TEST RIG





Bloodhound@University Web-Portal

- Open access philosophy –
open to all HE staff to
contribute to
- Built on UWE E-Learning
system that enables multiple
perspectives on data
- Vehicle, Design Lifecycle, ...
 - Flexible reuse of information



<http://bloodhoundssc.uwe.ac.uk/RenderPages/RenderHomePage.aspx>



Simulator



- Primarily as an engagement tool – not a design tool !
- Southampton – adaptation of MicroSoft Flight Sim
- UWE body shell



So what's special about Bloodhound ?

- Bloodhound will provide unique access to data throughout the lifecycle of the project.
- Rich source of educational material – not only the details of the designs – but also an insight into the thinking/ rationale of choices
- Ideas that worked –
– and some that didn't !

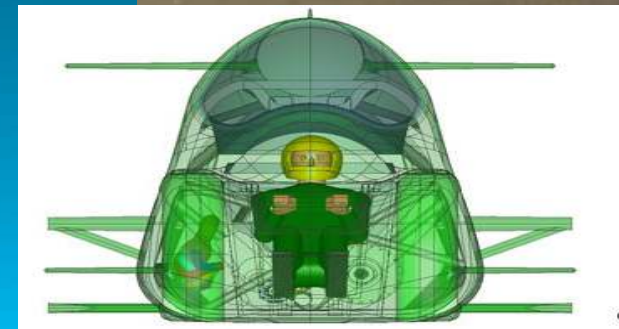
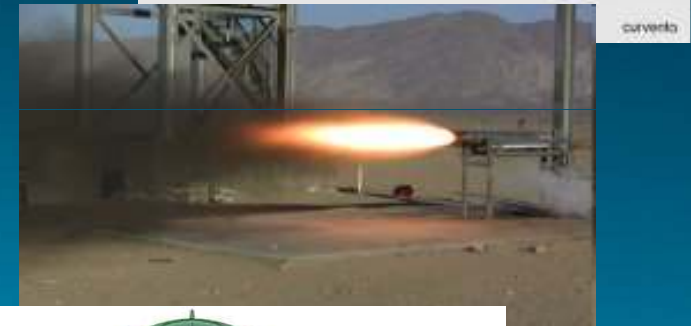
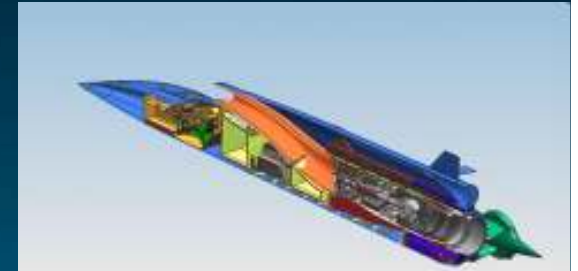



Integrated Educational Perspective

- STEM is more than just Technology & Engineering
- Project Management
 - What are lessons learnt for other R&D activities
- Environmental dimensions
 - What is impact of a project such as this ?
- Pedagogic aspects
 - How can we better teach 21st C STEM students in the future ?
 - What is the role / contribution of the Web / IT ?



BET - Design Team Interface

- Design Team – John Piper – Design, Build and run car.
- Education Team - Dave Rowley – communicate information about the project across education spectrum.
- Tony Parraman – Educational Liaison – link between Design & Education teams



Industrial Relevance & Opportunities

- Partnerships – key element of Bloodhound
 - Collaboration for mutual benefit – for Education and for Industry
- Continuing Professional Development Opportunities
 - Aspects of BH@Uni could be used as very effective CPD support materials
 - Portal could provide on-demand access to staff and companies
- Specialist guidance / authoring support from industry
- Collaborative Funding Bids



Where next ?

?

That's what today is about



The Bloodhound Legacy ?

- What can we learn from this project – as educators – that we can apply to other areas of our teaching activities ?
- How can we exploit / use / develop IT based approaches to enhance and enrich aspects of our teaching ?
- What's the next Bloodhound ??