

# Novel business practices

A presentation by **Ultimate Synergy** ( Group 2 – Tutor: Dr Andrew M Gravell )

## Speakers:

Roberto Gregoratti, Adam Barrett, Matthew Searle, Jacob Causon, George Davies, Jiaxin Shen, Alex Kumaila

April 22<sup>nd</sup>, 2013 – University of Southampton



Roberto Gregoratti



Adam Barrett



Jiaxin Shen



Jacob Causon



Matthew Searle



Alex Kumaila



George Davies

We are Ultimate Synergy!!

The members of our tutor group

# Novel business practices: an introduction

Adam Barrett

# What are novel business practices?

In the age of the **dot com boom**, many companies are required to **employ new strategies** to keep up with **competitors**, most of which revolve around the use of **available computing technology**.

Take the example of GoldCorp Incorporated; a Gold mining company based in Vancouver, Canada...



# Tough times...



In 1999, Rob McEwen, the CEO for **GoldCorp Inc.** , was facing a crisis 😞

The company's **profits** were at a **standstill** and the many geologists the firm employed were **unable to find any exact locations** and furthermore quantities of gold

With **belligerent shareholders** on his case, he decided he had to take **radical action**: he employed a **novel business practice**.

# A different approach

In March 2000 the “GoldCorp Challenge” was launched.

Amid much scepticism, in a bold move McEwen ordered that **all** of the company’s **geological data** on the company’s 55,000 acre property was **published for all the world to see**.

\$575,000 in **prize money** was offered for the **best solution/estimates**

News of the contest spread rapidly, attracting the attention of **many would-be prospectors**. Ranging from experts in Physics to Computer Graphics.

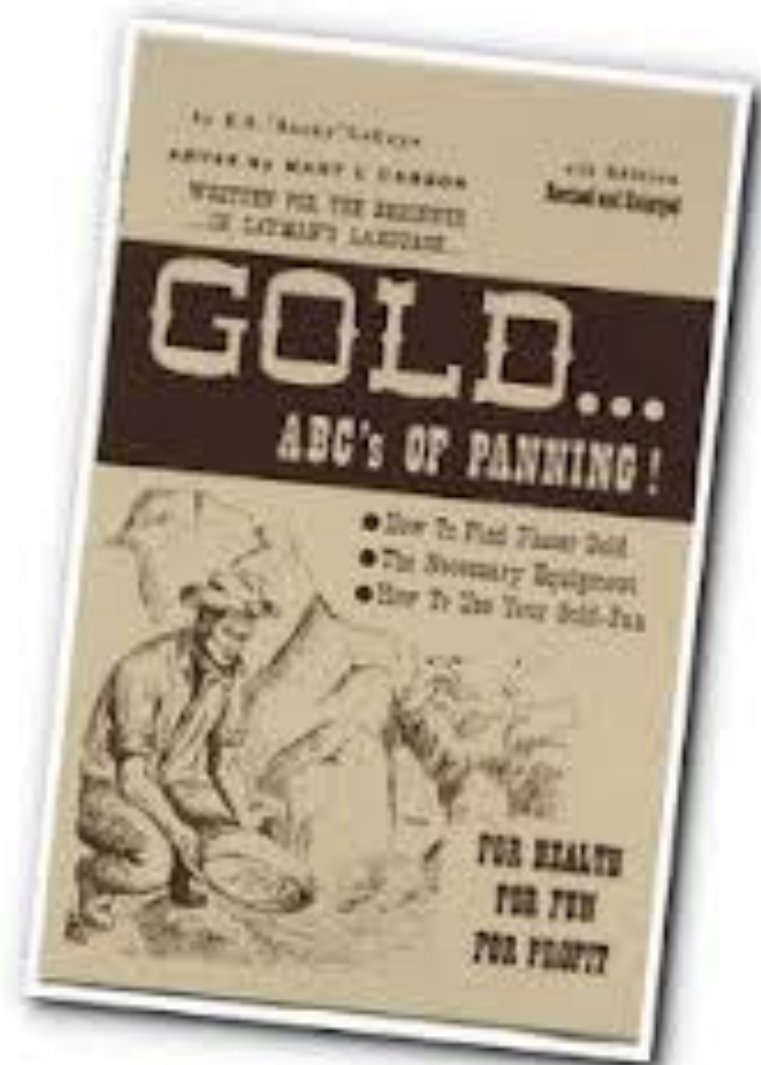

# What happened?



The contestants identified over 100 targets on the Red Lake property, 50 percent of which had not been previously identified.

80 percent of said targets yielded massive quantities of gold.

McEwen's approach to the problem transformed GoldCorp from a struggling \$100 million dollar company into a **\$9 billion dollar power-house**. *He did good.*

**One hundred dollars** invested in the company in 1993 **was worth over \$3,000 dollars today.**



# And why is this important??

In the **'cut-throat'** world of business, many companies are forced to employ **new tactics** that depend on **technology** to try and **keep the cutting edge**.

Another example of a company which outsources via IT is **Procter and Gamble** who get **50% of their business ideas** from **external innovators** who submit their ideas via the **P&G portal**, at [http://www.pgconnectdevelop.com/home/submit\\_innovation.html](http://www.pgconnectdevelop.com/home/submit_innovation.html)

There are however well established views that this new use of technology is a **threat to the legitimate right of companies to make a profit**. Take the mass-engineered project – Linux for example.

Companies that fail to devise **new methods of generating profit** and **exploiting available technology** are at risk of failure. When was the last time anyone bought a CD? 😊.



# And so what, today? Why would I want to listen, you might be asking yourself?



Ultimate Synergy's aim is to look at the various **ways technology is employed in the workplace** and the subsequent consequences.

Our topics range from **technology in business pre-production** to **technology in finance** with a focus on the **technical/social aspects** of each.

# Novel business practices: Pre-production

Matthew Searle

# Computer Aided Design (CAD)

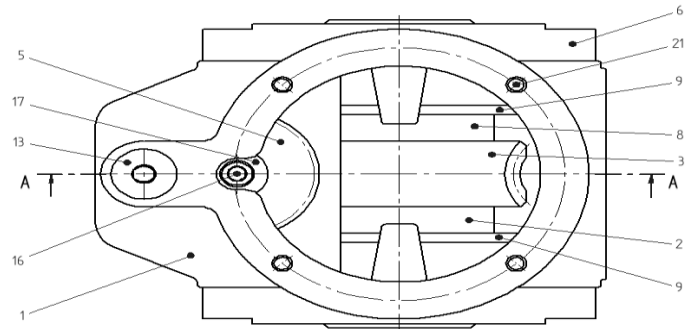
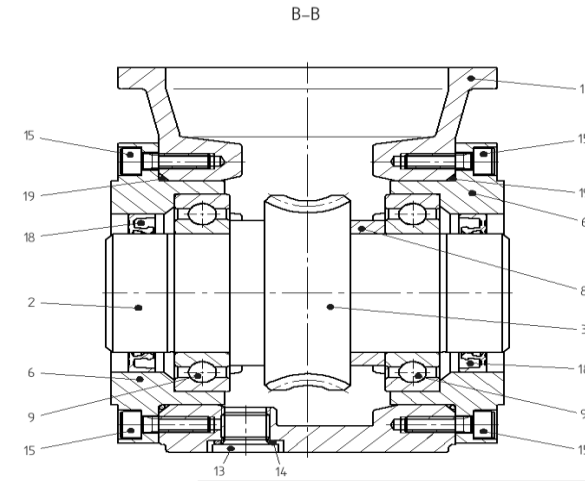
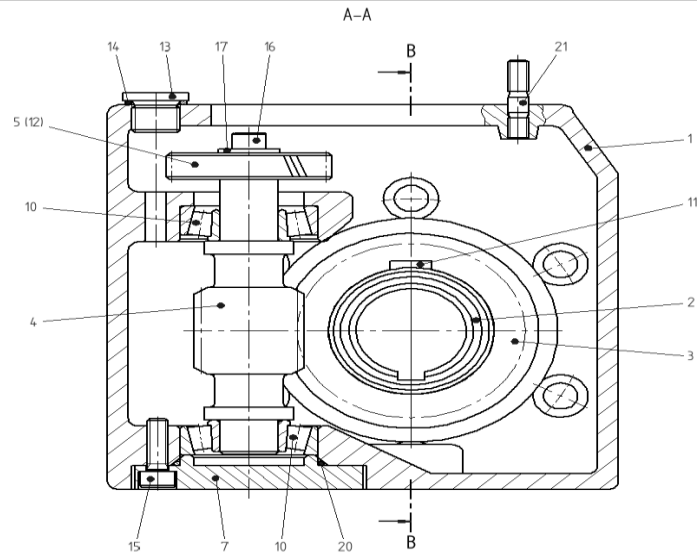

1	2	3	4	5	6
Pos.	Menge	Einheit	Benennung	Sachnummer / Norm - Kurzbezeichnung	Bemerkung
1	1	Stck.	Gehäuse		G - AlSi10Mg
2	1	Stck.	Hohlwelle		34CrMo4
3	1	Stck.	Schneckenrad		G - CuSn12Ni
4	1	Stck.	Schneckenwelle		16MnCr5
5	1	Stck.	Zahnrad		16MnCr5
6	2	Stck.	Lagerdeckel groß		S235JR
7	1	Stck.	Lagerdeckel klein		S235JR
8	1	Stck.	Distanzring		S235JR
9	2	Stck.	Rillenkugellager	DIN 625 - 6009	
10	2	Stck.	Kegetrollenlager	DIN 720 - 30203	
11	1	Stck.	Passfeder groß	DIN 6885 - B 12 x 8 x 22	
12	1	Stck.	Passfeder klein	DIN 6885 - B 5 x 5 x 10	
13	2	Stck.	Verschlusschraube	DIN 908 - M14 x 15 - St	
14	2	Stck.	Dichtring	DIN 7603 - A 14 x 18 Vf	
15	15	Stck.	Zylinderschraube mit Innensechskant	ISO 4762 - M6 x 20 - 8.8	
16	1	Stck.	Zylinderschraube mit Innensechskant	ISO 4762 - M6 x 16 - 8.8	
17	1	Stck.	Scheibe	DIN 9021 - B 6.4	
18	2	Stck.	Radial-Wellendichtring	DIN 3760 - AS 4.5 x 60 x 8	
19	2	Stck.	O-Ring	DIN 3771-85x3,55-N-NBR 70	
20	1	Stck.	O-Ring	DIN 3771-40x3,55-N-NBR 70	
21	4	Stck.	Stiftschraube	Kaufteil gemäß Zeichnung	S235JR

  

Zust.	Änderung	Datum	Name
		20.03.2006	

Schneckengetriebe	
Blatt	1
von	10

# What is it?

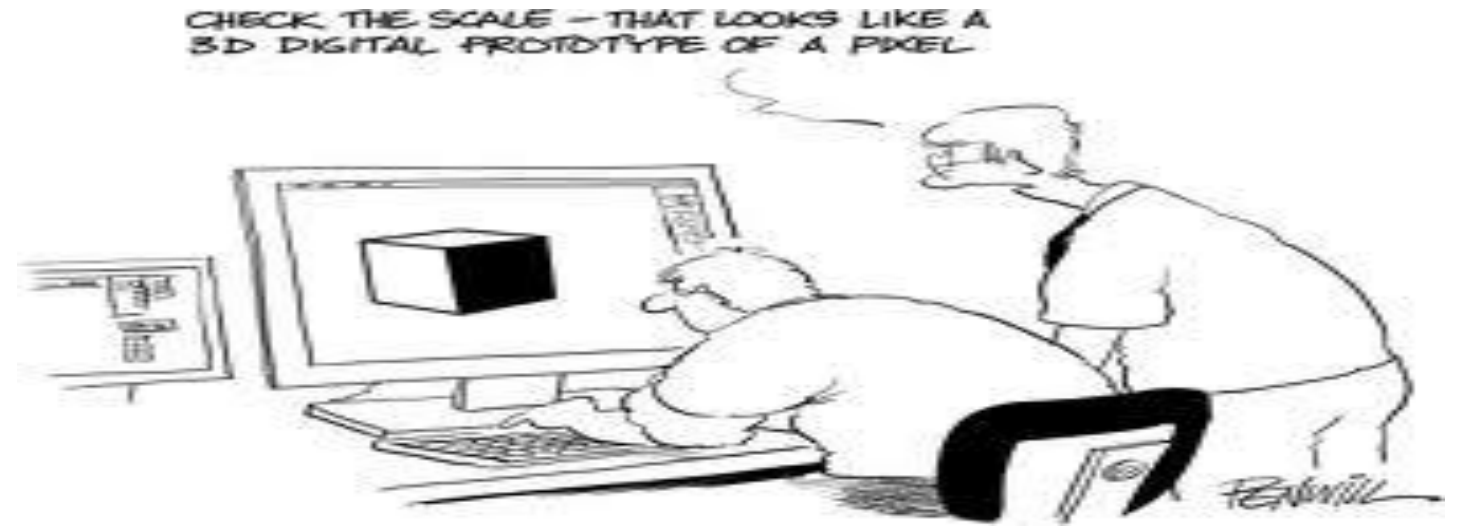

- “Computer-aided design (CAD) is the use of computer systems to assist in the creation, modification, analysis, or optimization of a design”
- **3 Dimensional drawing tools** in combinations with other technologies such as **3D printing** allow Engineers to **test principles and concepts** in a whole new way.
- 3D printing means that engineers can **prototype throughout the design process** and actually get their **hands on models of the end product** which in the past may have been too difficult to model to scale.

# How has it improved upon the old method



Beginning in the 1980s **computer-aided design programs** reduced the need of **drafters**.

- Drafters were **specially trained artists** that would sit at drafting boards and create **accurate, scaled drawings** of the **designed product**.
- The drafters would have to draw **many different variations** of the given design for architects and engineers to argue over **before the final design** was decided upon.
- Now the models having been designed on a computer can be much **more easily modified and assessed**.

- 3D models allow designers to almost walk around the space they are designing in
- Architects and Engineers can model the space and simulate sunlight to check for light dispersion
- The computer is able to test whether the design is structurally safe
- This also give clients an accessible medium by which to imagine the finished product rather than a technical drawing

## Example application: Google sketch up

Google  
SketchUp PRO



# Novel business practices: Production

Jacob Causon









@YOUNGESTER...



# Automated production lines

- **Faster** and **more accurate** than a human
- Have **abilities** humans don't such as the ability to 'see' **infrared** and **x-rays**
- Doesn't need to take **breaks** or be **paid**
- Has had an **impact** on the **unskilled labour market**
- Will need new, **expensive skilled** employees to **manage the system**



# Automated production lines



- Only lead to **savings** when producing products **high volumes**
- Still has the **costs** associated with **transportation** from factory to consumer

These systems **can't be used everywhere** but when they can they can **change the way that the business operates** for the better

# Novel business practices: Working practices

Roberto Gregoratti

# How this all started... In the '90s

- 1990s: the Dotcom Bubble and the advent of the Internet account for new business models being developed by companies...

BUT...

- *“The business plans floated on the theoretical supposition of everyday interactivity failed because the experience turned out to be so clunky when real home users tried it out on dial-up computers.”*  
(Peter Day, BBC, 2003)
- Technology was not sufficiently developed to be deployed on a corporate level!!
- New business models started to emerge anyway, based on the **predicted growth of technology** in the industry...



# And where we are today...



- **100%** of the corporate world today uses technology to their advantage
- **Technology** at the heart of financial transactions, **employee development** programs, **career** progression and financial **success**
- Internet is the main platform for a company to **advertise** themselves!
- A **fully interconnected world**... new business model from the ground up



# Open and linked data usage

- Key principle: Open source movement and an ever-increasing amount of data are at the centre of the business world today...
- Increasing bandwidth and Internet resources = companies can use technology as their **development, outreach and deployment platforms**
- Automation of 90% of business services = **enormous quantities of data to handle**
- Everyday **interactivity** key of business success today
- **Linked data**: “a method of publishing structured data so that it can be interlinked and become more useful” . Similar concept: **open data**
- Companies are applying **transparency** in their business model. Data published on the Internet leads to more interactivity and cooperation
- Corporate cooperation = successful business practices and larger market shares. Collaboration = better, more popular products: **more resources, higher success**

# New ways of working / Productivity



- ❖ Trending practices: **homeworking** and **teleworking**
- ❖ ICT allows for **flexibility** on workspace and distance work
- ❖ Meetings and face-to-face projects can't be included in the scheme : a combination of **face-to-face and distance working** is proving prolific for some businesses
- ❖ Reduction of **costs** for employers
- ❖ **Hot desking** also developing for certain businesses

# Employee training

Company efficiency improved through **training for new employees**, by using:

1. **Technology** (training software, hands-on experience)
2. Custom, tailored **training packages**
3. **Collaborative** environments

## Strategy 1: Custom-designed training software

- ✓ Advantage: tailored, self-paced training.
- ✓ Disadvantages: lack of face-to-face training from experienced employees. Often costly (development). Not hands-on most of the time.
- ✓ Example: system functionality tutorials

## Strategy 2: Learn-by-doing approach

- ✓ Advantages: personal experience, contact with experienced personnel. No added cost for the company.
- ✓ Disadvantage: Often a lengthy process.
- ✓ Example: mentoring scheme

# Legal issues, data protection and intellectual property



- More technology = more **data**, more **legalities (patents, etc)**. Companies need to observe **laws** (Data Protection Act et al.) – **downside** of technology in corporate world
- Cooperation= productivity : growth of **open source products and services** (most famous startup model: Linux). Often this represent great revenue for the company
- **Creative Commons** licensing and cooperative model
- Need to **protect patents and intellectual property**:
  - ✓ 2012 – Record number of patents: 257,000+ Europe only
  - ✓ **Intellectual property** most valuable asset for a company
  - ✓ Copyright and severe restrictions on **important products**

# Novel business practices: Logistics

George Davies



# Logistics



- Logistics is defined as “the detailed **organization and implementation of a complex operation**”<sup>1</sup>
- When relating **logistics to business**, it evaluates to the **management of transportation, storage and stock of products.**

# Transportation

- 34 million vehicles are registered on Great Britain's roads<sup>1</sup>.
- In 2010 there were 1,966 million tonnes of freight lifted in Great Britain, with 1621 million tonnes of this going by road<sup>1</sup>





# Transportation



- **Satellite navigation** has evolved to allow businesses to dynamically adapt to daily road conditions.
- The **efficiency** of modern **delivery** provides **faster delivery** using **less employees**.

# Stock management

- To build a **successful assembly line**, the **materials** must arrive in the **correct quantity** at a **time** before they are needed.
- By using **technology driven delivery**, materials can be delivered **within a time frame**. To ensure that there is the correct quantity of materials at the location, **stock management** is needed.



# Stock management



- Using a **technological solution** such as a **database** can **nullify the need for a dedicated employee** responsible solely for this purpose.
- This process **reduces the reliance on one person** and **increases reliability of stock ordering**

# Storage management

- Businesses have a **finite amount of storage** space.
- A company must ensure that the storage space they do have is **effectively managed** so that there is a **balance** between the **volume of stock being sold** and the **volume being produced**.



# Storage management



- The **warehouses** distributed across the planet must maintain a **varying range of products** to **increase the availability** of a product **globally**.
- By maintaining a **global-stock database** versus a **location based database**, a business can effectively **ship its products from factories and warehouses** to enable an **even global distribution** of its products is maintained.

# Novel business practices: Communication

Jiaxin Shen



# Technical aspect

## Smart meetings

- Software programme
- Easy to share content and capture ideas in powerful, engaging ways

## Instant communication

- Instant messaging
- Allow two or more people contact in one time
- Reduce time of consumption





# Social aspect

## Translation

- Enable a larger market
- Make simple and easy understand

## Network

- Git
- LinkedIn



# Novel business practices: Finance

Alex Kumaila

# Online transactions

## \* Electronic Commerce

✓ “A type of industry where **buying and selling** of either product or service, is conducted **over electronic systems**.”

## \* The introduction of ‘E-tailing’

✓ **Virtual store fronts**, sometimes gathered into a ‘virtual mall’.

## \* Expands potential customer bases of **B2B** and **B2C** sales.

## \* A safe way of payment; **SSL encryption** covers **current conventional methods** (Visa, PayPal .etc).



# Bitcoin



- \*A **digital currency**, first introduced in 2008.
- \***Peer-to-peer payment** system.
- \*Creation and transfer is completed over **open source encryption protocols**.
- \***Not managed by a central authority**. (Anarchism, Micro-philanthropy)
- \*Acquired through either **exchange or mining** (the procedure of using your own computing power to process and maintain the security of Bitcoin transactions, and/or crunching onerous mathematical equations).
- \*Slowly becoming **more and more accepted** as a payment method.
- \*An **anonymous transaction**, often used in online black-markets. (Silk Road)

# The loss of a 'middle man'

- \* Two key **business benefits**:
  - \* Reduced paper trails.
  - \* Faster and more **accurate forecasts** of revenues and expenses.
- \* **Increases productivity** within business, no need for human intervention for every transaction.
- \* With **ease of payment** comes ease of decision, pushes **more sales**.

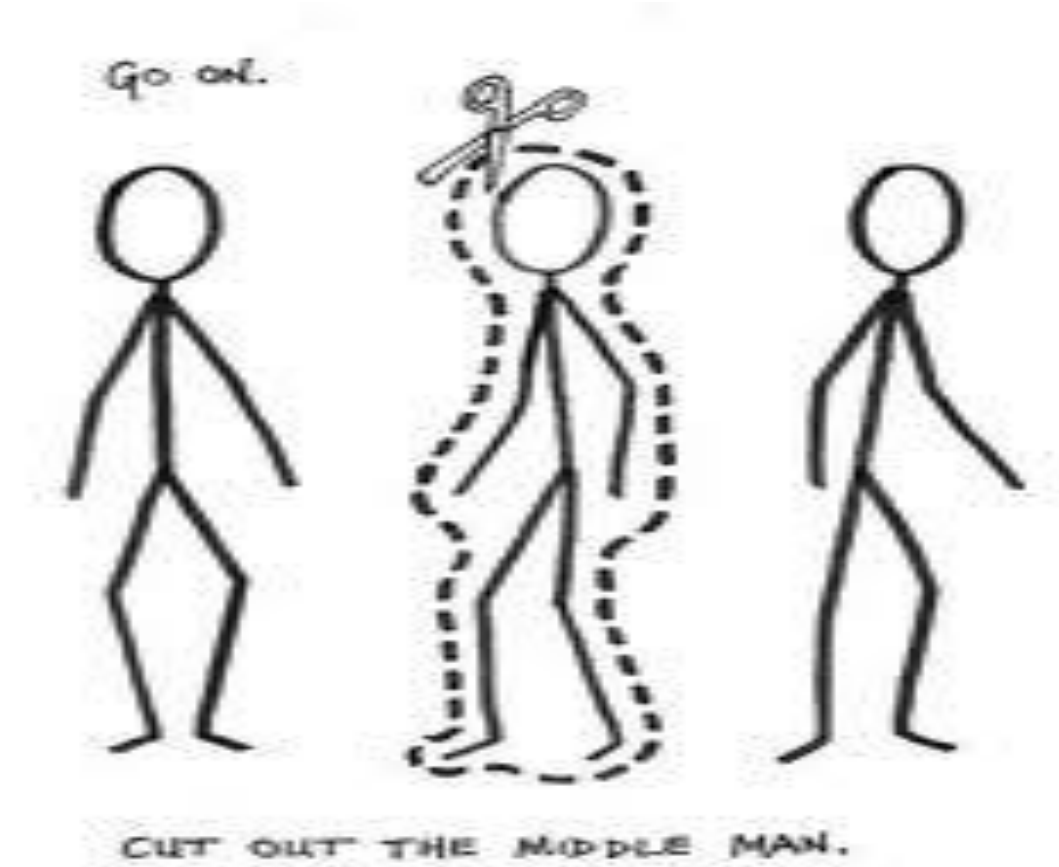

# Fees



- ✱ Some online transfers, however, entail **levels of fees which hinder global payment growth.**
- ✱ Payments which include currency exchange are often charged an **exchange commission.**
- ✱ This can, in many cases, **sway the decision of the customer,** as **complication and lack of value** is introduced to the transaction.

# Novel business practices: the conclusion...

We might end here, but this is just the beginning...



# Conclusion...

- ✓ What we have presented today is just a **small part of the application of technology in the creation of new business models in today's corporate world**
- ✓ Technology is being employed in business to **create successful products, increase the productivity and efficiency of the existing models and generate more revenue by introducing cooperation with other companies and other innovative business models**
- ✓ There are many more issues for further exploration and discussion!!



## From Ultimate Synergy...

... thanks for listening!!

(And if you want to know where we got the inspiration from, check our references in the next slide!)

# Sources / References

- "Robotic equipment in the meat industry" , Graham Purnell (1998) <http://www.sciencedirect.com/science/article/pii/S0309174098900560>
- "Present and future robot control development - An industrial perspective", Torgny Brogardh (2007) <http://www.sciencedirect.com/science/article/pii/S1367578807000077>
- <http://news.bbc.co.uk/1/hi/business/6280489.stm> - Peter Day, BBC, Here comes the creator economy
- <http://www.slideshare.net/mylideshare/intellectual-property-and-trade-mark> - Intellectual property and trade mark presentation (patents and licensing section)
- <http://blog.swirrl.com/articles/linked-data-business-models> (open data)
- <http://www.slideshare.net/missdunlop1/working-practices-2008452> (productivity, working practices)
- <http://www.trainingindustry.com/content-development/articles/training-best-practices-and-organizational-success.aspx> (employee training)
- <http://www.businessperform.com/> (workplace practices)
- <http://www.epo.org/news-issues/press/releases/archive/2013/20130306.html> (patents and licensing)
- Department for transport, TSGB04 - Freight, Table TSGB0401, <https://www.gov.uk/government/statistical-data-sets/tsgb04-freight>, accessed 18/2/13)
- Oxford dictionaries, <http://oxforddictionaries.com/definition/english/logistics>, accessed 18/4/13)
- <http://smarttech.com/Home+Page/Solutions/Visual+collaboration+solutions/Products/SMART+Meeting+Pro+software> - SMART Meeting Pro software
- <http://git-scm.com/> - Git
- [http://www.linkedin.com/static?key=what\\_is\\_linkedin&trk=hb\\_what](http://www.linkedin.com/static?key=what_is_linkedin&trk=hb_what) – What is LinkedIn
- BBC News - <http://www.bbc.co.uk/news/technology-22152213>
- Daily Anarchist - <http://dailyanarchist.com/2011/10/02/i-was-wrong-about-bitcoin/>